

**INFINUVO**

**CleanMate**

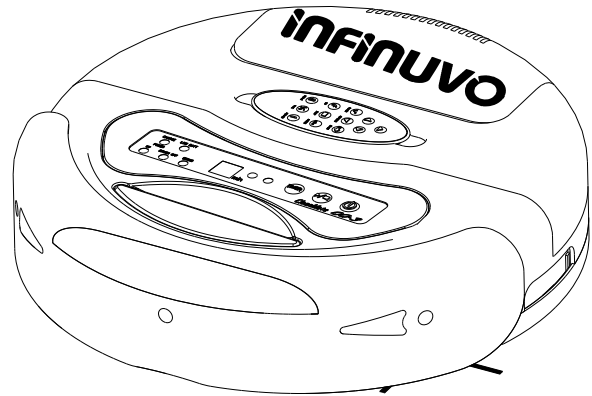

# QQ3 Series

Robotic Vacuum Cleaner

**METAPO**



If you have questions or issues on the product, do not return it to the store.

Please contact technical support with live chat at:  
<http://cleanmate.metapo.com>  
or visit [www.infinuvo.com](http://www.infinuvo.com)

REV.A 011513

**INFINUVO**

**CleanMate**

# QQ3 Series

Robotic Vacuum Cleaner

# USER MANUAL

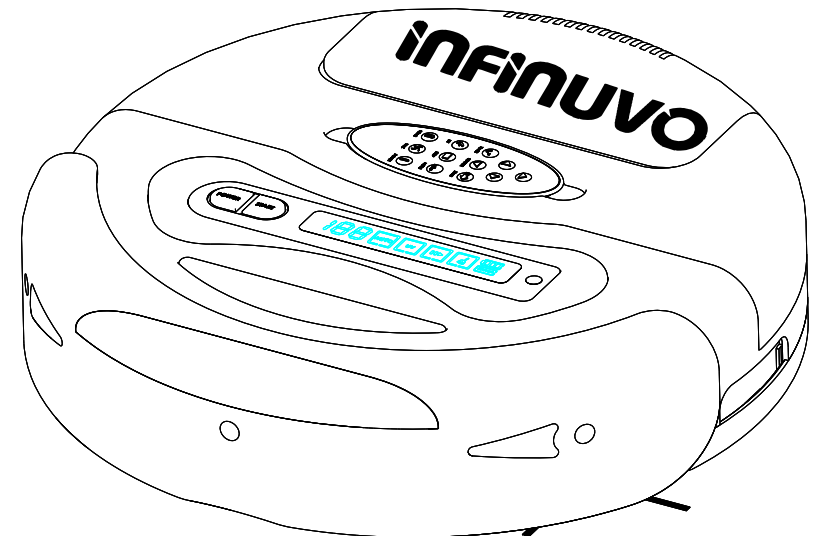

<b>Safety Precautions</b>	<b>1</b>
<b>Safety Instructions</b>	<b>1</b>
<b>Special Features</b>	<b>2</b>
<b>Cautions</b>	<b>3</b>
<b>Main Unit and Accessories</b>	<b>4</b>
<b>Main Unit Features</b>	<b>5</b>
<b>Control Panel</b>	<b>6</b>
QQ3-T Control Panel	<b>6</b>
QQ3-LT Control Panel	<b>8</b>
<b>Remote Control Functions</b>	<b>9</b>
<b>Battery Installation and Removal</b>	<b>11</b>
<b>Recharging the Battery</b>	<b>12</b>
<b>Scheduler Operations</b>	<b>14</b>
<b>Installing Accessories</b>	<b>18</b>
<b>General Operation</b>	<b>20</b>
<b>Cleaning and Maintenance</b>	<b>21</b>
<b>Useful Tips</b>	<b>24</b>
<b>Specifications</b>	<b>26</b>
<b>Troubleshooting</b>	<b>27</b>
<b>Warranty Policy</b>	<b>28</b>
<b>Appendix</b>	
How to Use Optional Sonic Wall	<b>29</b>

**\*\* Before using this product, please remove 2 white protection pads inside the front bumper. \*\***

Please follow all normal safety precautions to avoid the occurrence of situations such as fire, short-circuit, and injury. Please make sure that you observe all the following safety precautions:

## Safety Instructions

1. Read this user manual thoroughly before using this product.
2. This product is not for use outdoors.
3. This product is an electronic device. Never get it wet or let it come in contact with water. Do not use it in a moist or wet environment. This is to prevent damage to the electronics in the unit.
4. Before using this product, please tidy up things on the floor. You must remove all objects that could get caught in the roller brush or in the air intake on the bottom of the unit. Examples include, clothing, power cords, cable, telephone cords, drapes or blinds, loose fringes of rugs. These items can get caught in the unit, and either prevent it from moving, or the unit could pull over a lamp, table, or chair (for examples) and cause damage to the unit, floor, object, or person.
5. Please do not sit or stand on this product. Pay special attention to toddlers or pets in the house to prevent damage to the unit or the child or pet.
6. Please do not use this product to clean a still-burning cigarette, a lit match or burning embers.
7. Please do not use this product to clean flammable or highly volatile liquids such as gasoline or white gasoline.
8. To prevent damage to the vacuum, make sure that nothing is obstructing the air vents on the top of the unit.
9. When not in use for long periods of time, the power switch must be turned off.

## Safety Instructions

**INFINUVO**

10. When using rechargeable batteries, please use the correct voltage and current listed on the product. If you are not sure about the standard voltage, please ask your distributor or query the local electricity company.
11. Use the factory-provided CleanMate battery and charger.
12. When your hands are wet, do not touch the battery charger, plug or power cord.
13. When you need to clean this product, turn it off; unplug the charger, and remove the battery.

## Special Features

**INFINUVO**

1. This product is a robotic vacuum cleaner that utilizes high vacuum suction, two roller brushes on the bottom, a side brush for cleaning along walls and an ultraviolet light to help with disinfection. All of these features make this unit perfect for cleaning a wide variety of floor types, including ceramic tile, hardwood, vinyl and most carpets. As long as you have the Infinuvo Robotic Vacuum Cleaner, you have the most helpful house cleaning mate.
2. The compact shape enables this unit to clean under beds, tables and other furniture that standard upright vacuums cannot get to.
3. Once the CleanMate is turned on, it will follow a five step repetitive movement: Special bounce, Spiral, Along Wall, "S" shape, and Polygonal Spiral. This wide variety of movement helps to ensure that the unit completely cleans a room.

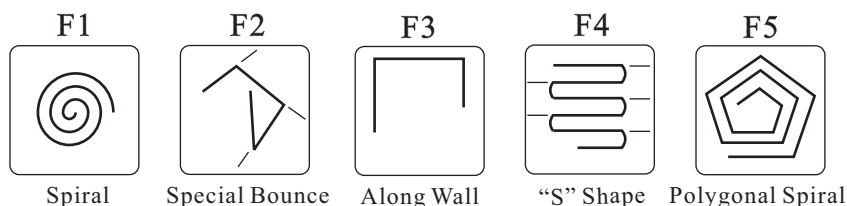

## Special Features

**INFINUVO**

4. "MODE" button on the remote control allows you to select a specific cleaning pattern for the CleanMate. By default the unit operates in Automatic Mode (switches between all 5 patterns), but by using the "MODE" button on the remote, you can select a specific pattern in the following sequence: 1.Spiral 2.Special Bounce 3.Along Wall 4.'S' Shape 5.Polygonal Spiral and back to A.Automatic.  
Note: when mode 4 "S" shape in use, if the CleanMate in 45 degree angle get into 90 degree wall corner and stuck in the corner, please use remote control to switch other mode ( in auto mode the CleanMate will change to another mode automatically every 30 sec).
5. Sensors at the front of the unit tell the CleanMate when it comes in contact with a wall or other obstacle, to back up, turn and clean around the object.
6. Photo sensors, under the front bumper of the unit, detect stairs and other drop offs, to keep it from falling off the edge and damaging the unit or anything else.
7. A handle is built-in to the unit to make it easy to pick up and move the unit to a different room.

## Cautions

**INFINUVO**



Do not look directly at the UV light.



Do not touch the UV light bulb with bare hands. Natural skin oils will cause premature failure.

Do not attempt to remove or replace the UV light. This light is a permanent fixture and is not user-replaceable.

# Main Unit and Accessories

**INFINUVO**

No.	Description	QTY
1	QQ3-T/QQ3-LT Main Unit	1
2	Remote Control	1
3	Filter	2
4	Rechargeable Battery	1
5	AC Charger	1
6	User Manual	1
7	Self-Charging Station	1
8	Sonic Wall (Only comes with QQ3-LT II)	2

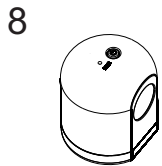
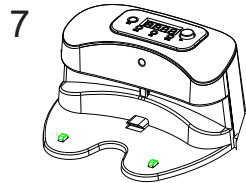
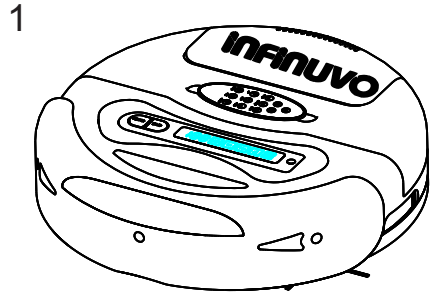
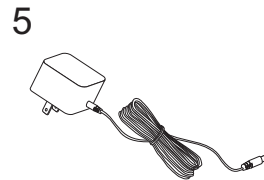
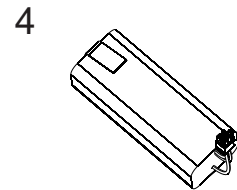
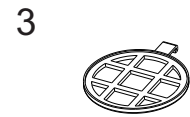
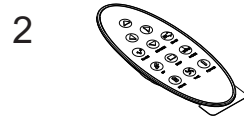
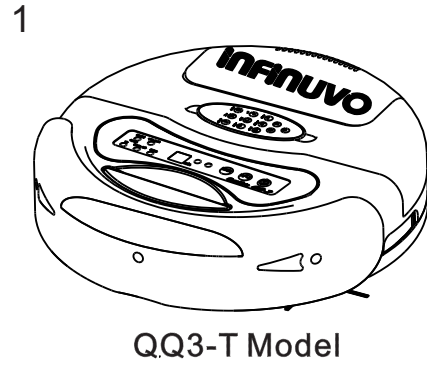

# Main Unit Features

**INFINUVO**

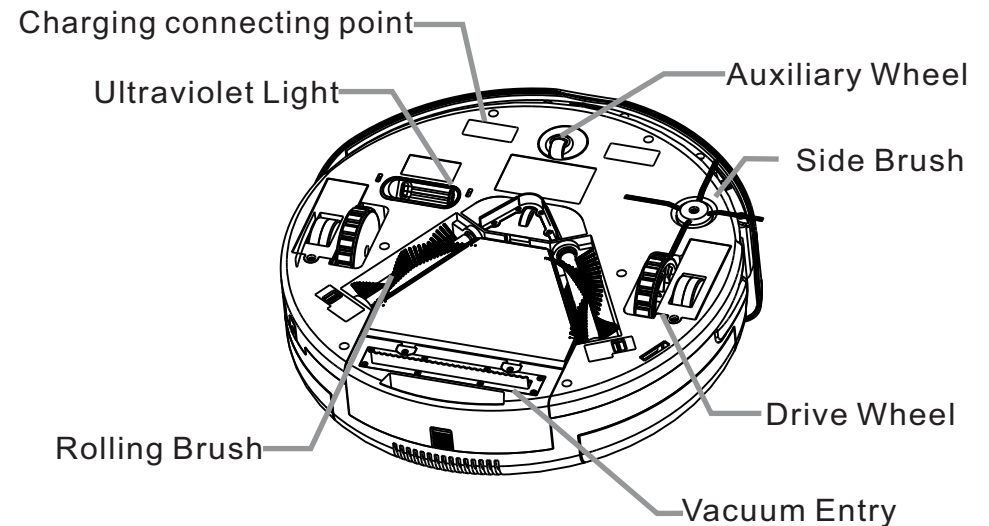
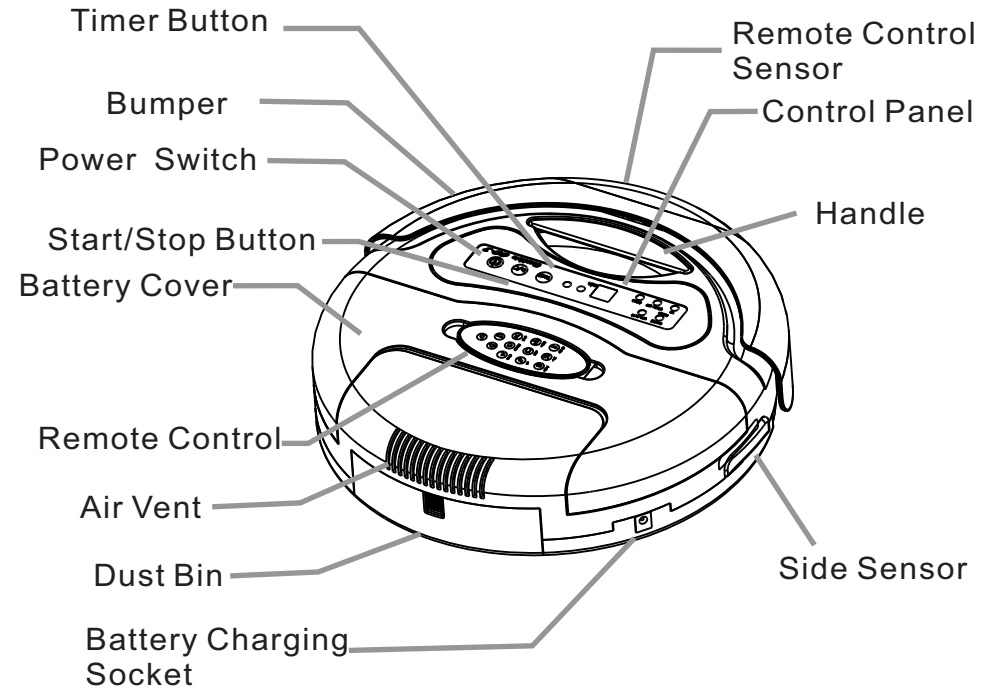

1. Press “POWER” button on QQ3 to turn it on. The power LED (solid blue) will light up.
2. Press “Start/Stop” button once on QQ3 unit to start the cleaning. Press this button again to stop cleaning.
3. Press “TIMER” button on QQ3 unit to set the operation running time. The numerical panel on QQ3 will display the running time & cleaning mode. When QQ3 is powered on for the 1st time, default running time is set to 90 minutes. User can change running time from 10 to 90 minutes in 10-minute intervals by pressing the TIMER button.
4. Set CleanMate running time based on the size of cleaning area. Regularly remove the debris and hairs around brushes and wheels to conserve battery power and increase battery life time.
5. When the battery power is low, the LOW BATT light on QQ3 will blink in red.
6. In the following situations, ERROR light will light up: battery over charging, motor overloading, and wheel traction losing (lifted off ground, etc) for more than 3 seconds.

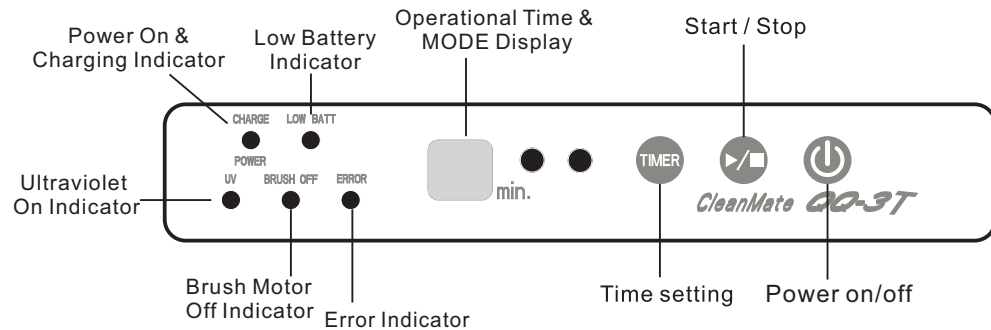

## LED and Audible Alert Indicators

### Audible indicator

Status	Description
Long Beep once followed by one Short Beep	Times up (when the cleaning timer was set) Battery Low, cleaning function off
Long Beep once	Error
Short Beep three times	Fully charged
Short Beep three times and One long Beep	Fully charged and start vacuuming again (when the docking station is set that after fully charged, QQ3 will go out to vacuum again)

### LED indicator

Color of LED Lights	Description
Green	Steady – Brush Motor Off
Red	Blinking – Battery Low
	Steady - Error
Blue	Steady – Fully Charged / Power On
	Blinking - Charging
Yellow	UV On

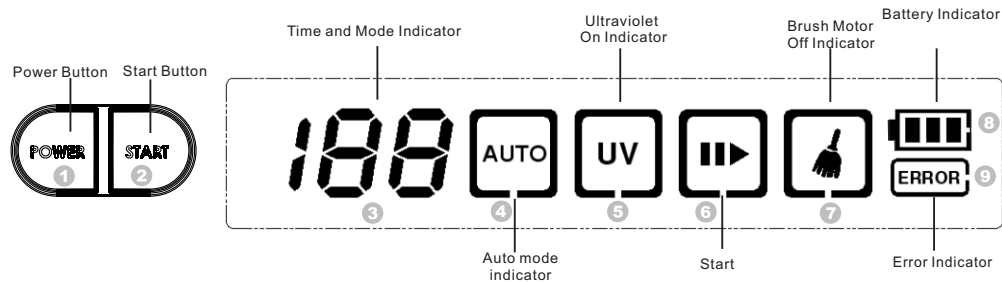

### LCD Control Panel and Functions

1. Power Button: To turn on QQ3LT
2. Start Button: To start QQ3LT
3. Time and Mode Indicator: The numerical panel on QQ3LT will display the running time & cleaning mode. When QQ3LT is powered on for the 1<sup>st</sup> time, default running time is set to 90 minutes. User can change running time from 10 to 90 minutes in 10-minute intervals by pressing the TIMER button on remote control unit.
4. Auto: Light up when the cleaning patterns are repeated automatically
5. UV: Light up when QQ3LT UV light is activated via remote control unit.
6. Start: Light up when QQ3LT started working
7. Sweep: Light up when the brush motor is turned on by starting QQ3LT; light off when brush motor is turned off via remote control unit.
8. Battery indicator:

Battery indicator	Battery Status
Three Cells	Fully Charged
One Cell	Battery Low
Blinking	Charging

9. Error: Light up when battery over charging, motor overloading, and wheel traction losing (lifted off ground, etc) for more than 3 seconds.

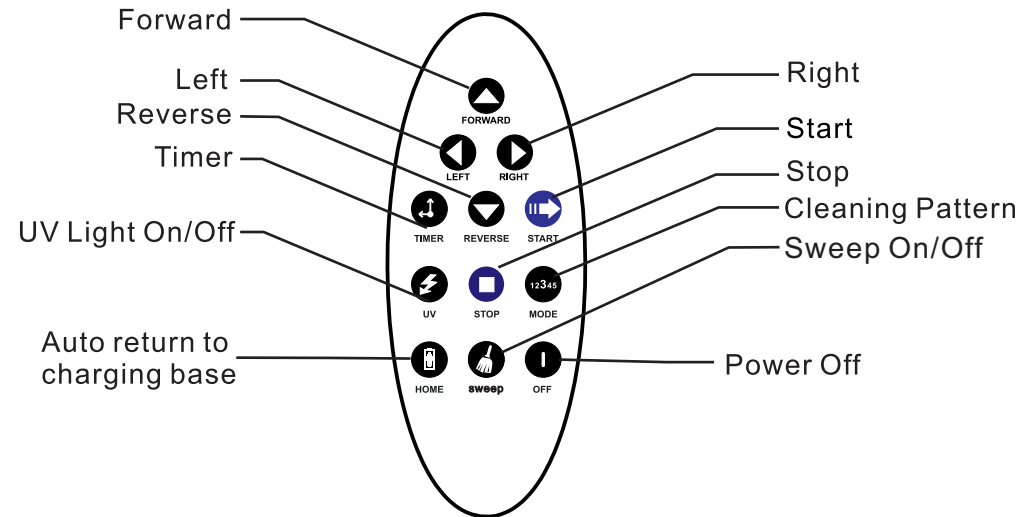

***\*Make sure to remove the insulation plastic sheet under remote battery before using the remote for the first time.***

### Remote Functions :

1. START button: Press START to begin the automatic cleaning of your room.
2. STOP button: Press STOP to stop the operation of QQ3. You will hear a long beep sound.
3. TIMER button: Press TIMER to change the cleaning time.
4. Direction buttons: FORWARD: when you press this button, QQ3 will move forward until user press FORWARD again, or when it hits an obstacle. RIGHT, LEFT and BACKWARD buttons: press these buttons to manually drive the QQ3 unit to go to right, left or backward directions.

5. **MODE button:** Press this button to select 1 of the 5 available cleaning mode patterns. The default operation mode is Automatic mode. In this normal mode, the CleanMate will go through all 5 pre-programmed cleaning patterns automatically to achieve the best cleaning effects. Presses MODE button one more time to select another cleaning pattern.

- Press “MODE” button once (1<sup>st</sup> time) to choose “Spiral” mode. The timer on QQ3 will display “1” for one minute and then show the cleaning time setting. When QQ3 hits an object while running in this mode, it will stop the movement and wait for further instruction.
- Press “MODE” button again (2<sup>nd</sup> time) to choose “Special Bounce” mode. The Timer on QQ3 will display “2” for one minute.
- Press “MODE” button again (3<sup>rd</sup> time) to choose “Along Wall” mode. The Timer on QQ3 will display “3” for one minute
- Press the “MODE” button again (4<sup>th</sup> time) to choose “S Shape” mode. The timer on QQ3 will display “4” for one minute
- Press the “MODE” button again (5<sup>th</sup> time) to choose “Polygonal Spiral” mode. The Timer display on QQ3 will show “5” for one minute
- Press the “MODE” button again (6<sup>th</sup> time), and the QQ3 will go back to the default Automatic cleaning mode. The Timer display on QQ3 will show “A” for one minute

6. **UV button:** Turn the UV light ON or OFF on QQ3.

7. **SWEEP button:** Press this button to turn brush motor ON or OFF. When to turn off brush motor (only perform vacuuming)? If the room is not too dirty and does not have large debris, vacuuming will be sufficient to do the cleaning and conserve battery power.

8. **HOME button:** Press this button to direct the QQ3 to return to self-charging station.

9. **OFF button:** Press this button to turn OFF the QQ3.

Remove both bumper protection foam pads before first use of the CleanMate unit.

Remove the insulation sheet under remote control unit battery before using the remote control for the 1<sup>st</sup> time.

Battery installation – open battery cover, connect the battery wire connector to the connector on QQ3 unit, put battery securely in battery compartment, and close the battery cover.

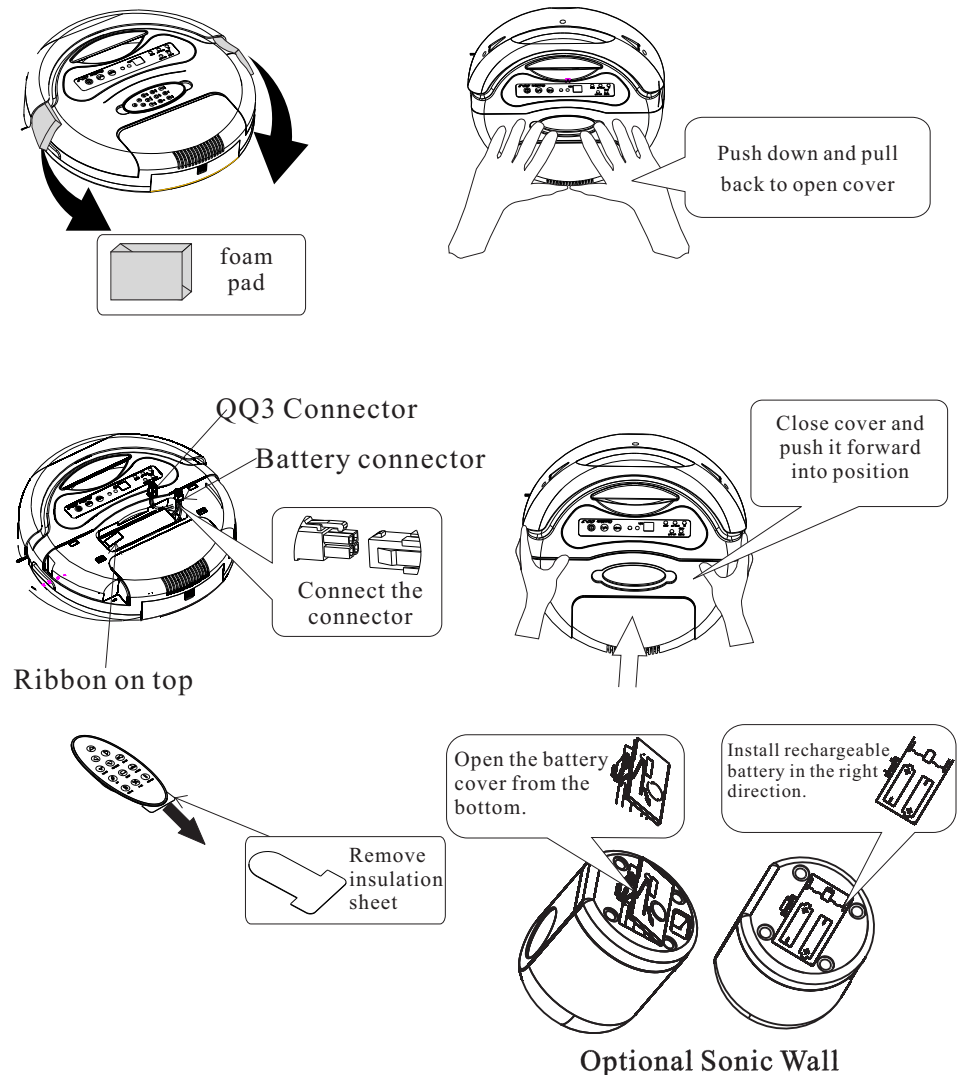

# Recharging the Battery



## Charge the battery on Self-Charging station (home charging base)

Make sure battery charger connector is plugged to the power socket on charging base first, and then plug the other end of charger to wall outlet.

Position charging base securely against the wall and leave enough clearance space on both sides. Also make sure there is open space in front of the charging base for QQ3 to dock onto the base.

Put QQ3 unit about 2.5 ft (or less) in front of charging base, and press "HOME" button on remote control to let QQ3 automatically dock to charging base and charge the battery.

Blue LED light on QQ3-T or battery icon on QQ3-LT will be blinking to indicate that battery is being charged. It normally takes about 3 hours to have the battery fully charged. It is recommended to charge the CleanMate battery overnight before first use.

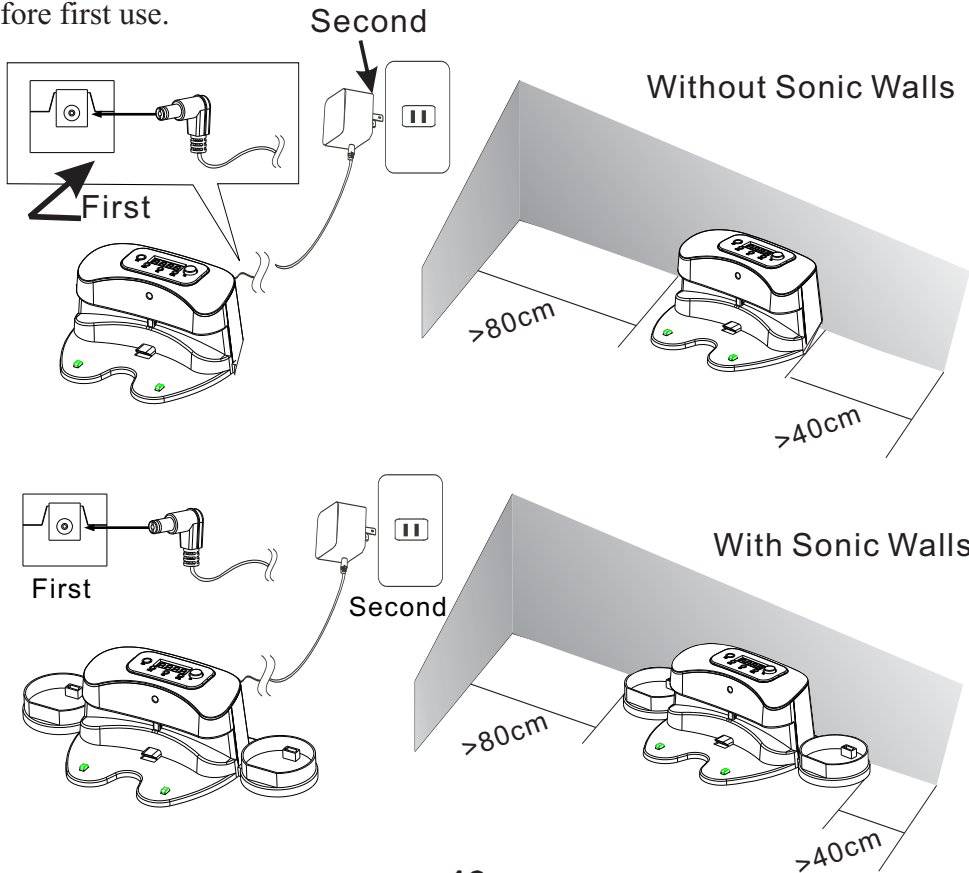

# Recharging the Battery



## Charge battery manually (without using home charging base)

To charge the battery manually without using charging base, just plug battery charger connector to the charging socket on QQ3 unit first, and then plug the other end of charger to wall outlet.

### QQ3T Model:

Blue LED light on QQ3T unit will be blinking to indicate that battery is being charged. It normally takes about 3 hours to have the battery fully charged. It is recommended to charge the CleanMate battery overnight before first use.

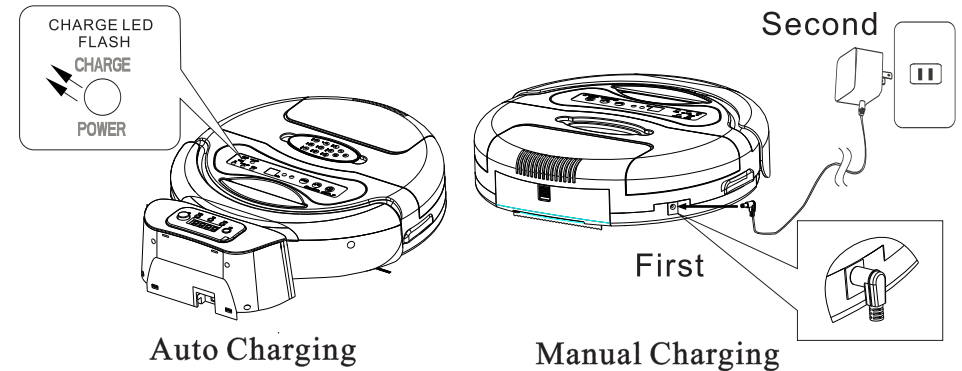

### QQ3 LT Model:

Battery icon on QQ3LT unit will be blinking to indicate that battery is being charged. When battery is fully charged, battery icon will be steady as shown.

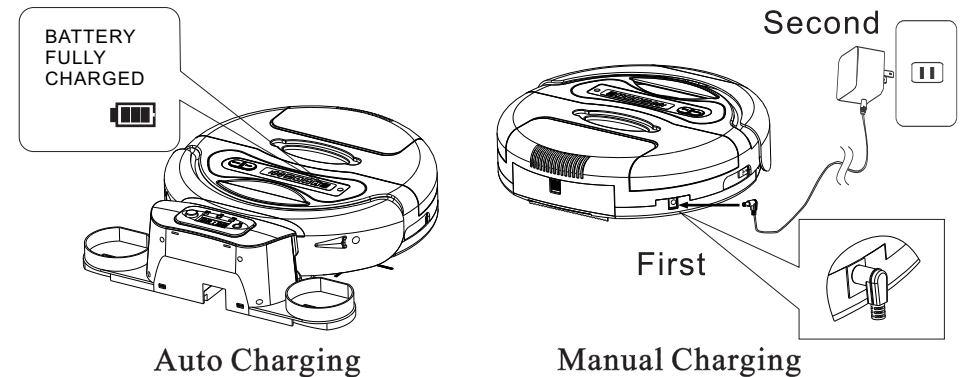



## Instructions on how to set up QQ3 Scheduler

With the help of scheduler on QQ3, user has the freedom to set up the cleaning time according to pre-programmed schedule. On the preset cleaning time, QQ3 will leave the charging base and start the cleaning session automatically. You can program it to start cleaning job at the same time on every day, or on any day of week you choose.

The scheduler LCD panel is located on the top of the QQ3 self-charging base unit. User needs to plug the AC adapter into QQ3 self-charging base, and set up the clock and cleaning times.

### 1. Illustration of QQ3 Scheduler LCD Panel

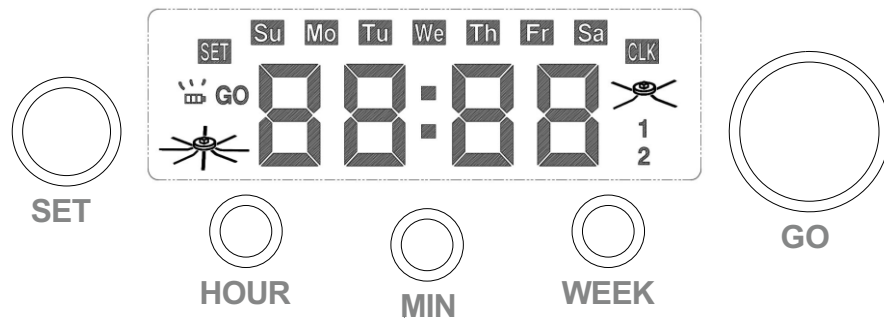

- SET (on left side of LCD panel) sign is displayed when you set clock or cleaning schedule
- Week display (top of LCD panel): Each week day display will be shown as “Su”, “Mo”, “Tu”, “We”, “Th”, “Fr” and “Sa”.
- CLK(Right side of LCD panel) is displayed in Clock-setting mode
- GO (Left side of LCD panel), Battery and Brush icon on the left panel show that the cleaning will start once the battery is fully charged.
- Brush Icon on the right side of LCD panel is displayed when scheduled cleaning time has been set up and it is ready to start cleaning based on preset schedule.
- Clock digit display is in middle of LCD panel.

## 2. Scheduler Setting Operations

### Setting the Clock

- 2.1 Once powered on, the scheduler will enter Clock Display Mode and display initial default setting of Sunday 00:00 (in 24 hours time format)



- 2.2 Press “SET” to set up the clock time (enter Clock-setting mode and display SET and CLK icon). Time and week will start blinking. Press “HOUR”, “MIN” or “WEEK” to set the correct time and week day. The display value will increase by “1” with each press, and the number will change rapidly if you hold the button.

The clock will be set and display will become steady (SET and CLK disappear) if there is no key input for one minute (idling or no action).

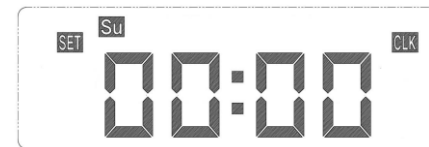

### Setting the Cleaning Schedule

User can schedule the QQ3 unit to clean on any day of the week, up to 7 days per week (one cleaning time per day and same cleaning time on each day).

- 2.3 Press “SET” again to enter Scheduler Mode. Time and week will start blinking. Press “HOUR”, “MIN” or “WEEK” to set the cleaning schedule. The display value will increase by “1” with each press, and the number will change rapidly if you hold the button.

When you set hours and minutes, the cleaning time will not be scheduled if you select the bar (“-” sign as shown below) instead of a numeric digit.

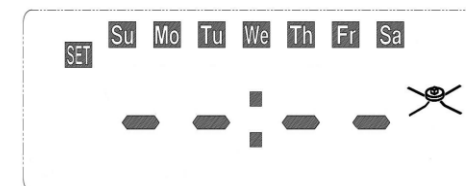

After cleaning time is set, you can choose to schedule the cleaning time on any day in a week. The initial default setting is to clean on everyday. Press “WEEK”, then the scheduler will highlight all 7 days of the week, which means the QQ3 will start automatic cleaning once a day, 7 days a week (at same cleaning time).

If you want to choose a particular day (or days) in a week to perform the cleaning job, then press “WEEK” again. You will see “Su” start blinking. Press “WEEK” one more time within 5 seconds if you want to select Sunday, and you will see “Su” turns into steady state to confirm your setting. If you want to select a day other than Sunday, just wait for more than 5 seconds and you will see “Mo”, or other days of the week. To select a particular cleaning day, just press “WEEK” within 5 seconds after you see it blinking to confirm. If you want to skip a day, wait for more than 5 seconds (without pressing “WEEK” key), and it will start display the next week day for you to choose.

2.4 When cleaning schedule set up is complete, press “SET” again and the scheduler will return to the Clock display Mode.

Example 1 (LCD display with brush icon) - Scheduler is set up to perform a preset cleaning job and current time is Monday 8:10AM.

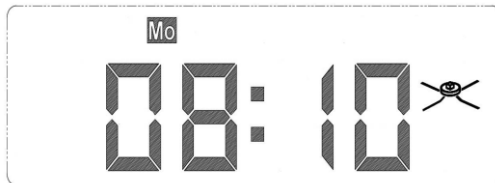

Example 2 (LCD display with no brush icon) - Scheduler has NOT been set up to do any preset cleaning job and current time is Monday 8:10AM.

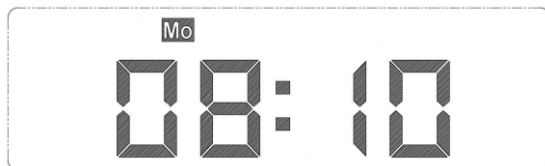

### 3. How to Delete a Preset Cleaning Schedule

When scheduler displays clock time (at Clock Display Mode), press “SET” once and it will enter Clock-setting Mode. Press “SET” again, it will enter Scheduler Mode.

When you set hours and minutes, the cleaning will be deleted if you select the bar (“-” sign as shown below) instead of a numeric digit.

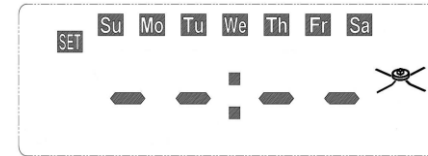

### 4. How to Display a Preset Cleaning Schedule

When scheduler displays clock time (at Clock display Mode), press “SET” once it will enter Clock-setting Mode. Press “SET” again, it enters Scheduler Mode and it also shows preset scheduling time and day.

### 5. Start Cleaning Automatically Right After Battery is Fully Charged

Press “GO” (for about 1 second) on the self-charging base, and you will see Battery, Brush and GO icons turned on (as shown below) on the left side of LCD panel. This indicates that the QQ3 vacuum will automatically start a cleaning cycle right after the battery is fully charged.

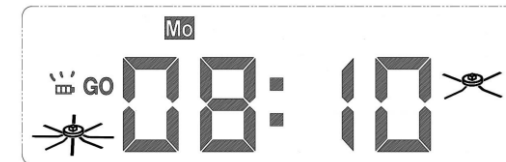

Press the “GO” button again to turn this function off.

**Note: QQ3 vacuum cleaner will only run one cleaning cycle after “GO” button is selected.**

## 6. How to Start Cleaning Right Away

If you hold down “GO” button for 5 seconds, the QQ3 on the self-charging base will leave the base and begin the cleaning right away, no matter whether the battery has been charged in full or not. This function works the same way as you push “START” button on the remote control on Section 7.

## 7. How to Start Cleaning with Remote Control

When the QQ3 is charging on the self-charging base, you can direct the QQ3 to begin cleaning when you press “START” button on your remote control.

## Side Brush Installation and Removal

- To remove the Side Brush, use a Philips head screwdriver to remove the screw in the center of the Side Brush Assembly by turning it counter-clockwise.
- To install the Side Brush, place the Philips head screw through the center hole of the Side Brush assembly, and align the screw with the hole in the slot for the Side Brush. Attach the screw by turning it in a clockwise direction, until the screw is firmly in place.

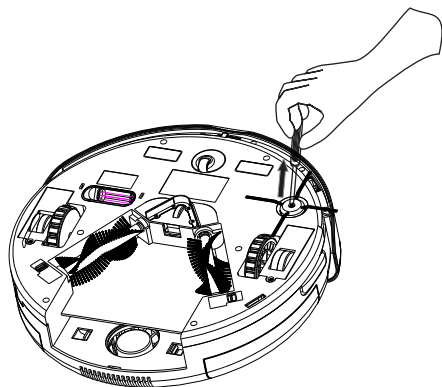

## Roller Brush Installation and Removal

Ensure that the power of the CleanMate is 'Off', and turn the CleanMate upside down so that the bottom of the unit is facing you. See Illustration below.

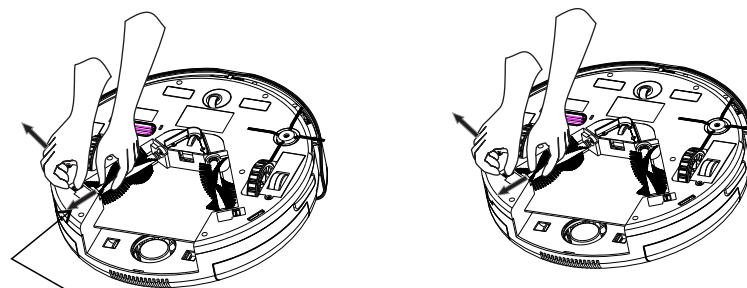

Push slide-switch with one hand and push roller brush with the other hand toward arrow direction and remove roller brush for cleaning.

Re-install roller brush: Roller brush has big head end and small head end. Push slide-switch with one hand and put big head end into hole under slide-switch with other hand then put small head end into other hole and release slide-switch to lock roller brush.

**Preparing for use**

1. Make sure you have completely charged the battery before using it for the first time.
2. Room preparation:
  - A. Pick up all large items off of the floor that could get stuck in the brushes or the vacuum intake.
  - B. Pick up/hide all cords that could get tangled in the unit.
  - C. Move all items that could be easily knocked over.
  - D. Roll under loose edges of rugs with any type of stringy fringe.
3. DO NOT use the CleanMate on plush or long pile carpet or rugs.
4. When using the CleanMate in a room for the first time, watch how it operates in the room. Watch for areas that the unit has troubles operating in, and either block these areas of the room or move objects around so that the unit can clean effectively and not get stuck or hung up before it has had an opportunity to clean the entire room.

**Starting Operation**

1. Clean out the dust bin before use.
2. Place the CleanMate on the floor in a relatively open space near the middle of the room to be cleaned.
3. Press the power button on the main unit to turn it on.
4. Set the timer of the unit to the desired cleaning time by pressing the Timer button on the control panel of the unit or on the remote control.
  - For Reference: Use 10 minutes of cleaning time for every 54-72 square feet of floor space.
  - Cleaning time may vary depending on the type of floor being cleaned.
5. Press the Start button on the control panel or the remote control. After a short delay, the CleanMate will begin to automatically clean the floor.
6. At the end of the cleaning cycle, the CleanMate will emit a long beep and will stop moving.
  - If the power light on the unit is still blue, then the unit still has battery power and can be used again.
  - If the low battery light on the unit is flashing red, then the battery is low and needs to be recharged before the unit can be used again.

**Stopping Operation**

- Press the Start/Stop button on the control panel of the unit or press the Stop button on the remote control.

*Caution! Please do not change the ultraviolet light tube yourself.*

**Cleaning and Maintenance**

The operation and maintenance of the CleanMate is very simple. To maintain top performance of the unit, it is recommended that you follow a routine cleaning and maintenance schedule after each use.

1. Make sure to clean and empty the Dust Bin and to brush off the Air Filter after every cleaning cycle.
2. Make sure that the vacuum intake is free of any debris and obstacles.
3. Make sure that the bristles of the Side Brush are free and not tangled with hair, etc.
4. Make sure that there is not hair, strings, etc caught up in the Roller Brush.
5. Remove and clean out the Roller Brush.
6. Make sure that there is nothing blocking the air ventilation exits on the top of the unit.

## Cleaning Dust Bin and Air Filter

Remove the QQ3 dust bin

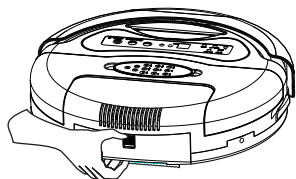

Push down black knob and pull out dust bin

Empty large garbage from dust bin A

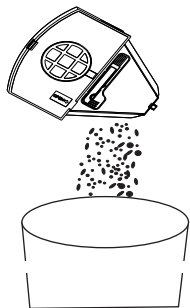

No need to open cover to empty dust bin A  
You can open cover to clean dust bin A if necessary

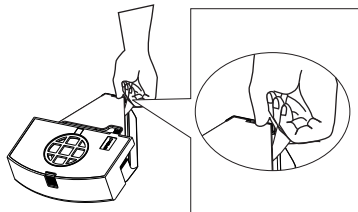

Open dust bin B cover

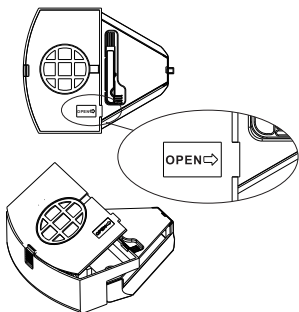

Empty small debris from dust bin B

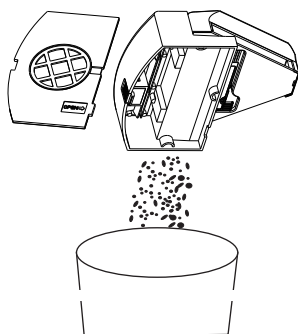

Use brush to clean filter

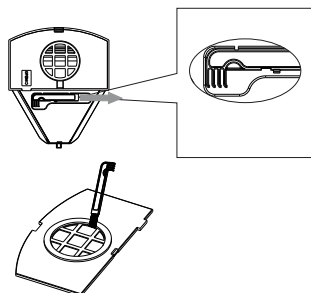

## Cleaning the CleanMate

Over time dust and dirt can accumulate in different areas of the unit, DO NOT use water to clean the unit itself! This is an electrical unit, and if any of the electric components get wet, the unit will no longer work, and could cause a short circuit and potentially harm someone. Use Canned Air, the Hand Brush provided with the unit, or a dry cloth to wipe away accumulated dust and dirt.

After operating the machine for a period of time, dust and dirt will accumulate on the vacuum entry on the bottom of the CleanMate. Cleaning this area regularly will help ensure that the unit performs properly.

1. Make sure the power of the CleanMate is turned off.
2. Turn the unit upside-down, and brush any dust that has accumulated inside the vacuum entry as shown below. Shake the dust out into a trash can.

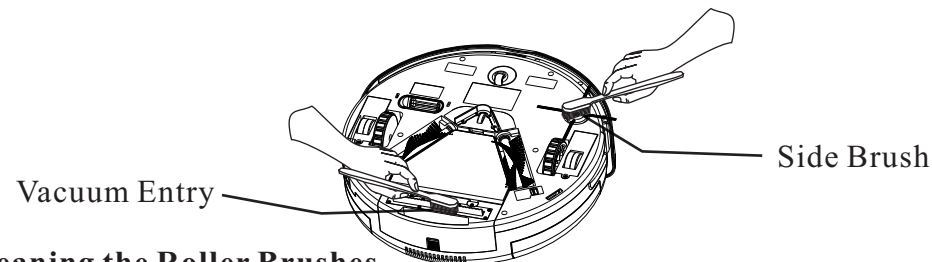

## Cleaning the Roller Brushes

Hair and other stringy items can get caught in the roller brushes over time.

1. Make sure the power of the unit is turned off.
2. Turn the CleanMate upside-down and place it on a flat surface with the back of the unit facing you.
3. Remove the Roller Brush from its compartment by sliding the switch lock to the left, grab the roller brush with the other hand and slide it toward the bottom of the unit until the upper end of the roller brush is free.
4. Lift the free end of the Roller Brush out of the compartment, then slide the Roller Brush to the top, freeing it from the flexible insert.
5. Remove any hair, string or other debris from the roller brush to ensure proper performance of the unit.
6. With the Roller Brush removed, loosen any dirt that has accumulated in the Roller Brush compartment with a brush, then dump the dirt into a trash can.
7. Re-install the roller brush following the steps outlined in Roller Brush Installation and Removal Section (P.19)

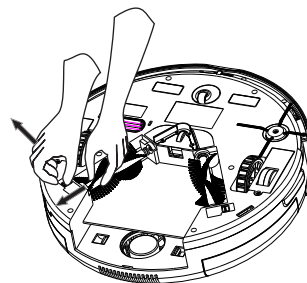

**Tip#1:** Clear the area where the CleanMate is to clean of any items can be easily knocked over or caught in the Roller Brush or Side Brush.

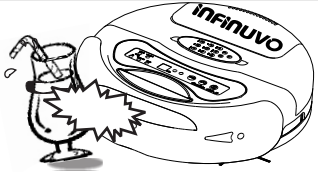

In the area where the CleanMate operates, it might knock over items such as vases, glasses, or lamps.

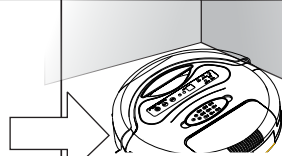

In order to provide the CleanMate a space for fast and safe cleaning, please remove small items from the area before operating.

**Tip#2** Adjust the distance between furniture, walls and other objects to be at least 36 cm (14 in).

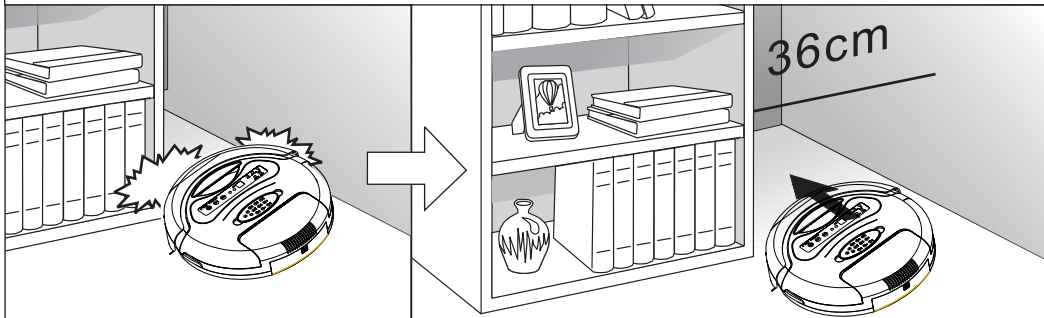

**Tip#3** Do not let the loose edges of rugs, drapes, table cloths, etc to get caught in the CleanMate. Roll under the loose edges of rugs and make sure that any table cloths, drapes, bedding etc do not hang down to the floor.

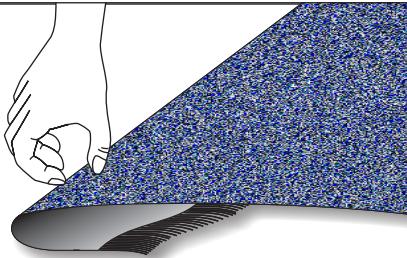

When the CleanMate is cleaning rugs, fold under the edges of the rug.

Remove plastic bags and leftover long-shaped garbage

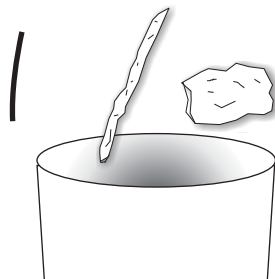

**Tip#4** Fixing jams: Objects can get caught in the Roller Brushes and prevent them from working properly. Immediately turn the unit off, clear the object causing the jam, and resume normal use.

Turn the Power switch of the unit to OFF.

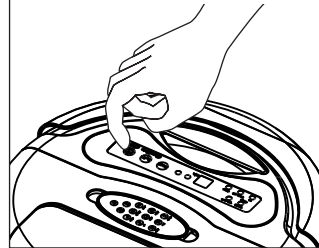

Turn the CleanMate upside-down, and remove the objects.

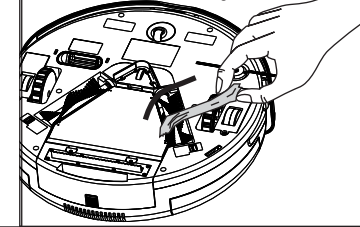

Clean the vacuum entry.

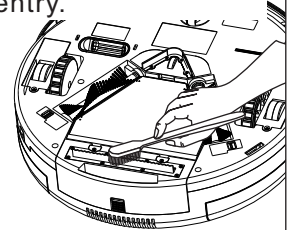

**Tip#5** Aim the remote control at the sensor on the front of the CleanMate. Anything blocking the signal will affect the performance of the remote control.

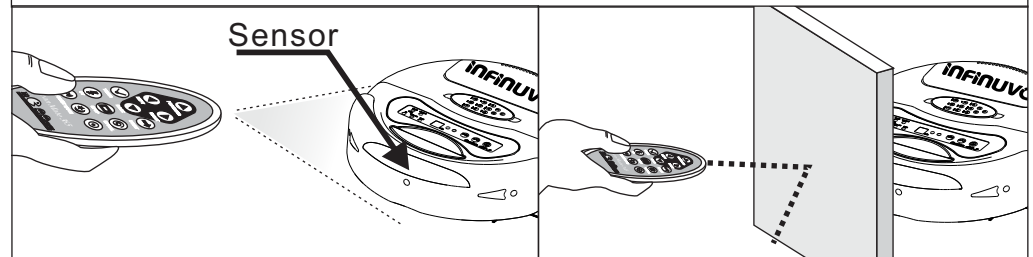

Item	Description
Suction Power Speed	9000 rpm vacuum motor
Fast adapter/charger	Output: 20Vdc 1000mA Input: 100 - 240V 50 - 60 Hz
Battery	Ni-MH 14.4V, Rechargeable, 3.5 hours of charging time 2000 mAh/2500 mAh
Noise	65dB at distance of 8 in
Life time of UV Light	6000 hours continuously
Capacity of dust bin	0.67 liter
Moving speed of machine	5 ~ 6 in/sec
Remote control	Infrared light with more than 3 meters controlling range, 3V button Lithium battery CR2032
Types of movement	5 types: Spiral, Special Bounce, Along Wall, S shape, Polygonal Spiral
Dimension	14inch (diameter) x 3 3/4 inch (H)
Weight	6.5 Lbs

This trouble shooting guide covers some CleanMate problems that you might have. If problem persists, please contact your local warranty provider or [www.infinuvo.com](http://www.infinuvo.com) for further assistance.

The repairs that marked \* needs to be done by qualified service personal.

Problem Symptoms	Possible Cause	Things to do
QQ3T-Both ERROR & LOW BATT indicators are on QQ3LT-ERROR icon is on	Battery installation problem	Make sure battery is connected tightly
	Battery malfunction	Charge battery manually for 2 days(see Page 13) or replace battery
QQ3T-ERROR indicator on QQ3LT-ERROR icon is on	QQ3 is lifted off ground over 3 seconds while running	Put QQ3 back on to the ground
	QQ3 is stuck	Remove debris & hairs from brushes and wheels
LOW BATT indicator on QQ3LT-ERROR icon is on	Battery power is low	Recharge the CleanMate battery
Cannot power on charging station, no data or wrong data on LCD display	Charging station malfunction	Replace charging station
Cannot dock on charging station	Place charging station on hard surface floor per instructions	User remote control HOME key to test docking
	Charging station malfunction	Replace charging station
Fall down steps or stairs	Cliff sensors malfunction	Clean cliff sensors
Always turning in circle counter clock wise direction	Left wheel malfunction	Clean or replace left wheel
Always turning in circle clock wise direction	Right wheel (close to UV light) malfunction	Clean or replace right wheel
Always going backwards	Bumper protection pads not removed	Remove bumper protection pads
	Front bumper sensor malfunction	Clean or replace front bumper sensor*
	Control board malfunction	Replace control board*
Main roller brush stuck	Too much debris & hairs on brush	Remove debris & hairs from roller brush. Replace roller brush if necessary
	Brush motor malfunction	Replace brush motor*
Side brush stuck	Too much debris & hairs on brush	Remove debris & hairs from side brush. Replace side brush if necessary
	Brush motor malfunction	Replace brush motor*
Remote control does not work	Remote control battery bad	Replace button battery in the remote control
	Remote control defective	Replace remote control
No cleaning power or air flow out from back of unit	Vacuum motor located above dust bin is not rotating	Check vacuum motor connection or replace it
Sparks when connect AC charger	Wrong AC charger connection sequence	Connect charger to QQ3 unit first then connect charger to wall outlet
Abnormal noise from vacuum motor	Air filter not installed properly	Check air filter is tightly in place

Please fill in your warranty card completely and submit it to your local customer service center.

Infinuvo provides you, as the owner of this Infinuvo product, with the following Limited Warranty Policy.

## One year Product Warranty:

Infinuvo warrants to the original purchaser of this Infinuvo product that the product is free from defects in original materials and workmanship for a period of up to one year from the date of initial purchase. This warranty is only valid if the product has been properly installed and is used in the way for which it is intended, and has received only factory-authorized repairs, servicing or alterations.

Under-warranty products that meet these conditions and that function improperly will be repaired or replaced, at the discretion of Infinuvo.

## Six months Battery Warranty:

Infinuvo warrants to the original purchaser of this Infinuvo product that the original batteries contained within this product will function for a period of six months. This warranty is only valid if the product has been properly installed and is used in the way of which it is intended, and has received only factory-authorized repairs, servicing, or alterations.

Under-warranty batteries that meet these conditions and that function improperly will be repaired or replaced, at the discretion of Infinuvo.

These warranties contain the sole express warranty of Infinuvo, which makes no other warranties, expressed or implied. These warranties are made in lieu of any implied warranties of merchantability or fitness for a particular purpose. These warranties give you specific legal rights. You may also have other rights, which vary from state to state.

WHEN YOU RETURN A CLEANMATE PRODUCT OR BATTERY UNDER THIS WARRANTY, you must first obtain an RMA number by calling your local customer service center or [www.infinuvo.com](http://www.infinuvo.com). Infinuvo reserves the right to request that you submit a letter describing the circumstances under which the problem occurred and that you submit invoice and any other supporting evidence and documentation.

The Sonic Walls create an invisible barrier that QQ3-LT II will not cross.

Only **QQ3LT II** has two Sonic Walls included on the package box. If there is no USB charging socket on your charging station, you can charge battery via your own AA battery charger.

**Sonic Wall usage restriction** – its signal coverage is in triangular shape (not a single line), therefore the blocked area will be large away from Sonic Wall location. This means some area near Sonic Wall will be blocked and not be cleaned by QQ3 unit. Sonic Wall placement and angle adjustment is required to achieve the optimal result.

Push down the power switch, “POWER” green LED is on and Sonic Wall works. Push power switch again will power off.

Sonic Walls can be set to block an area of 5 ft. long.

Sonic Wall beam is keyhole shaped. A larger triangular-shaped section blocks off areas of your home where you don't want QQ3-LT II to go.

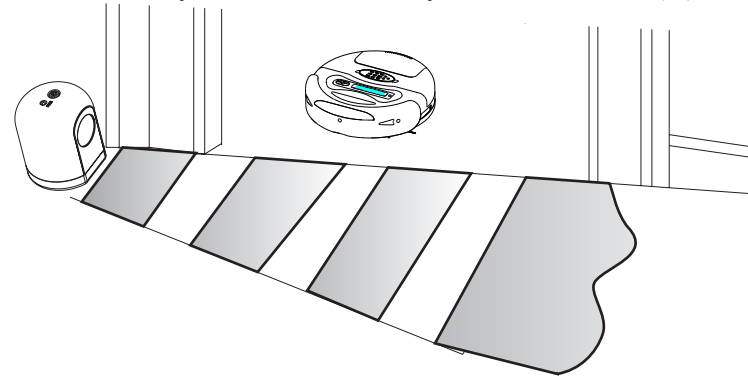

Use the Sonic Wall to block doorway and confine QQ3 to a single room cleaning.

If “POWER” green LED blinks, Sonic Wall battery needs to be recharged.

QQ3-LT II Charging Station has built in USB ports, you can dock the Sonic Walls into Charging Station to charge Sonic Walls AA batteries.

